



Economy Manifold Alert -2

Installation and Maintenance Manual

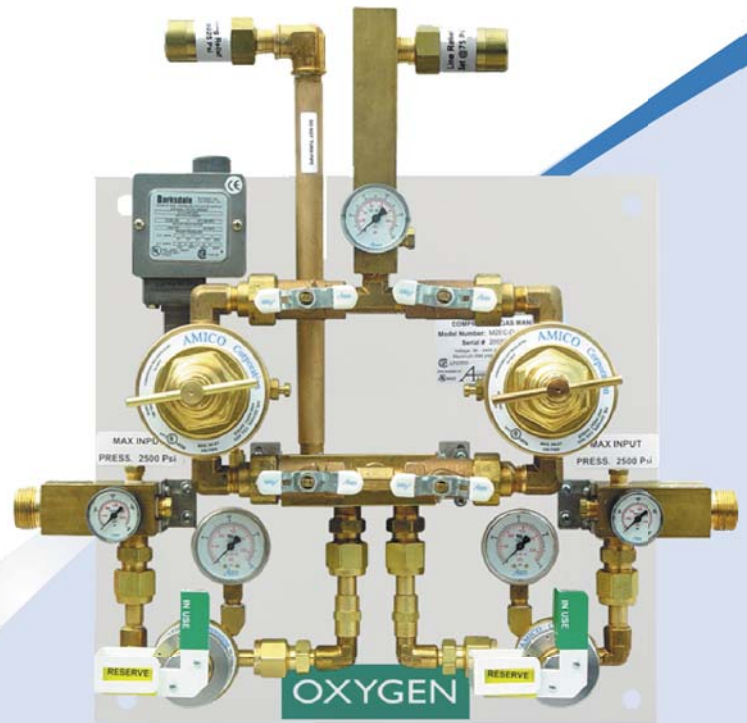

Table of Contents

User Responsibility	4
Introduction	4
Features	4
Description of the Manifold	5
Shipment Details	5
The Collapsible Back Bracket	5
Description of Parts	5
Common to all Economy Manifolds	5
Pressure Regulators (Operating & Line)	5
Pressure Relief Valves	5
Pressure Relief Valve Chart	6
Control Components	6
Operating Alarm Systems	6
Safety Features	6
Installation	7
Receipt and Location	7
Assembly Instructions	7
Cylinder Bank Instructions	7
Testing For Leakage	8
Final Testing	9
Set-up	9
Re-setting Line Regluators	9
Normal Operating Procedure	9

Maintenance	10
General	10
Amico Control Equipment	10
Cylinder Extension Bars	10
Periodic Standing Pressure Test	10
Trouble Shooting Guide	11
Cylinder Changing Procedures	12
Ordering Information	13
Economy Manifold Parts List	13-14
APPENDIX A - Economy Manifold Layout	15
APPENDIX B - Piping Schematic Diagram - NFPA	16
APPENDIX C - Wiring of Remote Alarm Buzzer	17
APPENDIX D - Support Bracket Hole Pattern Layout	18
Warranty Policy	19

User Responsibility

The information contained in this Installation and Maintenance Manual, pertains only to the ALERT-2 economy manifold. This product will perform in conformity with the descriptions contained in this manual, when assembled, operated, maintained and serviced in accordance with the installation instructions provided.

The manifold **MUST** be checked periodically. Parts that are broken, missing, worn, distorted or contaminated, **MUST** be replaced immediately. Should such repair or replacement become necessary, please contact Amico Corporation or their distributors.

All manifolds should not be repaired, or altered without prior written approval of Amico Corporation or it's distributors. Failure to comply will void all warranty on the manifold.

Statements in this manual preceded by the words **WARNING, CAUTION, DANGER** and **NOTE** are of special significance. Please read these sections carefully.



WARNING: denotes steps which can prevent injury.



CAUTION: denotes steps which can prevent damage to equipment.

Introduction

The Amico Economy Medical Gas Manifold incorporates the basic necessities for the distribution and monitoring of medical gases. The manifold has been designed to provide user flexibility and reliability. This manual will enable the customer to install, use and maintain the manifold properly.

The total amount of medical gas contained in the left or right banks is displayed on the analog gauges on either side of the manifold. These gauges are provided to show the cylinder bank pressure in use and the cylinder bank pressure in reserve at all times.

When the gas cylinder pressure depletes on the "In Use" (primary) side below the set point of the pressure switch, a signal will go to the master alarm (or remote buzzer) informing the hospital personnel that the "In Use cylinder bank pressure is low and the cylinders need replacement. At this point someone has to silence the alarm (or buzzer) and manually switch the "In Use" side to "Reserve" and the "Reserve" side to "In Use". To do this, simply turn the preset, clearly labelled handles on the operating (lower) regulators. Then proceed to change the cylinders. Changing the settings of the operating regulators will also reset the pressure switch and cancel the alarm condition.

***NOTE:** Always change the regulator settings BEFORE changing the empty cylinders.

FEATURES INCLUDE:

- Preset operating regulators for easy switch over
- Single or Dual line regulators
- CGA gas specified header bar with integral check valves and cylinder pigtail assemblies.
- High pressure header isolation valves.
- Manifold complies with NFPA-99. (Dual Line Only)

Description of the Manifold

SHIPMENT DETAILS

The package consists of one fully tested Alert-2 Series Manifold and a 3/4" isolation/source valve. Optional back support bracket, header bar assemblies, and pigtails are available.

THE COLLAPSIBLE BACK BRACKET (Optional)

The collapsible back bracket is designed to be shipped with the manifold, without taking up space. The bracket will position the manifold cabinet 12" from the wall, for double cylinder spacing.

Description of Parts

The ALERT-2 economy manifold is divided into (2) main sections:

COMMON TO ALL ECONOMY MANIFOLDS

1. PRESSURE REGULATORS

There are two types of regulators in the Amico manifold: the operating pressure regulator and the line pressure regulator. Both types conform to NFPA 99.

Operating (Source) Regulators

There are two operating regulators on every manifold, one for the left bank and one for the right bank. For Oxygen, Nitrous Oxide, compressed Medical Air and Carbon Dioxide service, the "In Use" regulator will be set at 160 psi and the "Reserve" regulator will be set at 120 psi. For Nitrogen the "In Use" regulator will be set at 250 psi and the "Reserve" regulator will be set at 200 psi.

Line Regulators

There are also one or two line regulators on every manifold. The line regulator is capable of maintaining a constant dynamic delivery pressure at the maximum design flow rate of the system (factory preset to "0"). For Oxygen, Nitrous Oxide, compressed Medical Air and Carbon Dioxide service, the line regulators should be set at 55 psig [379 kPa]. For Nitrogen service, the regulators are to be set at 170 psig [1172 kPa].

2. PRESSURE RELIEF VALVES

Pressure relief valves are installed downstream of all pressure regulators and are set at no more than 50% above the setting of the pressure regulator located immediately upstream. All pressure relief valves are capable of fully relieving the pressure at the set point and are upstream of any shut-off valve.

All pressure relief valves in the manifold have piping connections to allow for connection of vent.

Relief pressure settings vary with gas service as follows:

	Oxygen	Carbon Dioxide	Nitrous Oxide	Medical Air	Nitrogen
Line Pressure Relief Valve	75 psi [517 kPa]	75 psi [517 kPa]	75 psi [517 kPa]	75 psi [517 kPa]	225 psi [1551 kPa]
Operating Pressure Relief Valve	225 psi [1551 kPa]	225 psi [1551 kPa]	225 psi [1551 kPa]	225 psi [1551 kPa]	350 psi [2413 kPa]

3. CONTROL COMPONENTS

The Amico manifold qualifies as a “Cylinder System Without Reserve Supply” as classified in NFPA 99. This is one category of the broader classification “Central Supply System” which encompasses many types of sources of supply to nonflammable medical gas piping systems.

As such, the Amico manifold is comprised of two banks of cylinders which alternately supply the pipeline, each having various control components. When the primary bank is exhausted, the pressure drops as the secondary takes over. The pressure will stay low until the “Reserve” is manually switched to “In Use” and the “In Use” is manually switched to “Reserve”.

OPERATING ALARM SYSTEMS

Operating alarm systems are mandatory according to NFPA 99. Amico does supply a complete range of operating alarm units which can be used in conjunction with the Amico manifold, to provide the required visual and audible signals, in suitable locations, when change-over from the primary supply to the secondary supply occurs and cylinder replacement is necessary.

Mounted with the Economy Manifold is a preset pressure switch. Its function is to send a signal to the alarm unit when the operating pressure drops below its set point. For Medical Air, Oxygen, Carbon Dioxide, and Nitrous Oxide the pressure switch will be set at 140 psi. For Nitrogen the pressure switch will be set at 225 psi.

SAFETY FEATURES

Gas Service Identification

Amico manifolds are clearly labelled for the gas that they are intended to be used for. A large nameplate, indicating the appropriate gas is attached on the cabinet door. The two pipes extending from the top of the manifold, one for line pressure relief and one for the operating pressure relief, are labelled.

Cylinder Connections

The Amico manifold is designed to ensure that only cylinders containing the proper gas, can be connected to it. All cylinder extension bar connections as well as pigtail hose assemblies, comply with CGA Standard B96, “Compressed Gas Cylinder Valve Outlet and Inlet Connections.

Installation

RECEIPT AND LOCATION

The Amico manifold should be carefully examined upon receipt. If any damages are found, a claim should be filed with the transport company and Amico Corporation. Any authorized dealers and distributors should also be notified immediately.

ASSEMBLY INSTRUCTIONS

Wall Mounting Instructions

The Amico manifold is shipped in a semi-assembled condition to facilitate packaging and installation. Position the collapsible manifold support wall bracket (optional) onto the wall. Mark the holes, drill and place suitable anchors (not supplied by Amico), into the supporting wall (refer to "Appendix G"). Bolt the manifold support into position. Attach manifold to the support using supplied bolts. The back plate attaches to the front of the wall bracket.

CYLINDER BANK INSTALLATION INSTRUCTIONS

CAUTION: This section contains important information necessary for proper installation of the cylinder banks. Read it carefully before installing cylinder banks.

Position the wall brackets, if required, to support the extension bars and bolt in place. Connect the two high pressure inlet valve / header bar assemblies to the CGA connections on either side of the cabinet.

Secure the cylinder extension bar to the support using the U-bolts supplied as part of the assemblies. Remove the plug and chain assembly on each outlet connection on the cylinder extension bar. Attach the cylinder pigtailed to the header bar connections, while ensuring the check valves are operating in the proper direction.

When the medical gas piping system has been tested in accordance with **NFPA 99**, the manifold can then be connected to it.

The outlet pipes leading from the Amico economy manifold should be connected to their respective pipeline system connections. The connection to the relief valves should be made with a union (supplied by others) to facilitate change if required.

As the threaded joints are installed, an appropriate sealing compound that is suitable for the gas being transmitted shall be used.

Testing for Leakage

The following instructions apply to leak testing to be performed on the joints made during assembly and connection of the Amico manifold and not to tests previously made on the piping system.

The connections of the Amico economy manifold have been inspected at the manufacturing plant and DO NOT require leak testing. In order to determine whether any leaks exist between cylinder extension bar sections, or at the pipeline connections, the system must be pressurized using either oil-free dry air or oil-free dry nitrogen.

In the case of medical Oxygen, Nitrous Oxide or Carbon Dioxide Amico manifolds, the actual service gases **ARE NOT** suitable for leak testing due to their inherent dangerous properties. Leak testing must be performed using either oil-free dry air or oil-free dry nitrogen. In the case of either a Medical Air or a Nitrogen Amico manifold, the actual service gas may be used to perform the leak tests as follows:

3. Connect a cylinder of the manifold service gas to the end connection on each end of the cylinder extension bar using the copper or stainless steel cylinder connection hose assemblies (pigtailes) supplied.
2. Make sure all other outlets are capped with the plug and chain assemblies supplied.
3. Make sure that the high pressure inlet valves of each bank are fully **OPENED**.
4. **“Slowly”** open the two cylinder valves on either side of the Manifold, one at a time. To pressurize the cylinder extension bar and to pressurize the pipeline.
5. All outlets from the pipeline, downstream of the manifold should be closed and thus there should be no flow from the manifold.
6. Check for leaks at all cylinder extension joints and at the joints where the pipes were connected to the pipeline, using a commercial leak detector which is compatible with oxygen.
7. If any leaks are found, the system must be depressurized by bleeding through a convenient pipeline outlet and the faulty connections must be repaired.
8. The threaded pipe cylinder extension bar connections may be tightened one more turn, maintaining the horizontal location of the cylinder adapters, or a further application of an oxygen service threaded sealant may be required.
9. If the brazed pipeline connections leak, they must be removed, cleaned and then re-brazed following the proper technique. All repaired joints must be pressure tested as previously.

FINAL TESTING

Purging and analysing of the complete medical gas piping system shall be carried out in accordance with NFPA 99

SET-UP

Set one operating regulator to "In Use" and the other to "Reserve". With the high pressure inlet valves outside the cabinet both OPENED, S-L-O-W-L-Y open the cylinder valves on the cylinders closest to the manifold on the "In Use" side. After one minute S-L-O-W-L-Y open all other cylinder valves on that side. Then repeat the procedure for the "Reserve" side. A pipeline outlet downstream of the manifold such as a purge valve or terminal valve should be opened and vented safely, to produce a dynamic flow condition.

When both banks are open, check the inlet gauges to ensure that the correct pressure is indicated and that the left hand and right hand banks have full cylinder pressure. The line pressure should be 55 psig [379 kPa] for all manifolds except for Nitrogen, 170 psig [1172 kPa].

RE-SETTING LINE REGULATORS

Back to handle out by turning it counter clockwise and press the bleed valve until gas empties from the regulator. Then turn the handle clockwise until the desired pressure is reached.

NORMAL OPERATING PROCEDURE

Normal operating procedure for the Amico manifold entails connecting of the proper medical gas to all cylinder extension bar outlets via the appropriate copper cylinder connection hose assemblies.

With the high pressure inlet valves open, S-L-O-W-L-Y open the cylinder valves on the cylinders nearest the inlet valves on both banks. After waiting at least one full minute, allow time for the dissipation of generated heat, S-L-O-W-L-Y open all the rest of the cylinder valves, one at a time.

The bank that was pressurized first will become the primary bank by turning the handle on the corresponding operating regulator so it reads "In Use". The other operating regulator should read "Reserve". The High pressure inlet valves should be left open under normal operating conditions. In an emergency, these valves can be closed quickly.

Once the header bars have been pressurized, the Amico manifold is operating, since all regulators and control equipment have been set in SET-UP section. When the primary supply bank is exhausted and switch-over to the secondary bank occurs, the pressure switch notifies the person responsible, that the cylinders on the primary bank need replacing.

Be sure to change the operating regulator settings BEFORE changing the cylinders. To replace the empty cylinders with full ones, keep the high pressure inlet valves open throughout this procedure. Close all empty cylinder valves and remove them. Attach full cylinders in their place, then S-L-O-W-L-Y open the cylinder valve nearest the inlet valve and wait for at least one full minute before S-L-O-W-L-Y opening the remaining cylinder valves, one at a time.

The introduction of full cylinder pressure into the cabinet's main bar resets the pressure switch. The Amico manifold is then ready for the next switch-over.



WARNING: Fire Hazard. DO NOT permit smoking, or any other source of ignition in area where the manifold is located, or near the relief valve vent outlet. Be certain that all connections are free of dirt, grease and oil. These substances burn with great intensisty in air, enriched with oxygen, or nitrous oxide and some gas mixtures.

GENERAL

The tests and inspections specified below apply only to the Amico manifold and not to the medical gas pipeline system as a whole. They are intended to help ensure the proper operation of the manifold and not to be interpreted as repair instructions. Fault finding and repair procedures are given in the Trouble Shooting section of this manual.

AMICO CONTROL EQUIPMENT

Control equipment should be inspected and tested according to the following schedule:

1. Pressure Regulator:
 - A. Observe and record line pressure periodically.
 - B. Test for external leaks at least semiannually.
 - C. Switch line regulators monthly (if applicable).
2. Pressure Relief Valves:
 - A. Determine the pressure at which relief occurs at least annually and compare with the requirements of NFPA 99'.
3. High Pressure Inlet Valves (Manifold Hand Valves):
 - A. Inspect semiannually and test for external leakage and tightness of shut-off.

CYLINDER EXTENSION BARS

The following components shall be inspected semiannually as indicated:

1. Test check valves of pigtail assemblies for proper closure.
2. Inspect pigtail assemblies for apparent damage and thread damage to cylinder connections, replacing all damaged pigtails immediately.

NOTE: Replace ALL pigtails after 5 years service.

The cylinders and the operating pressure regulators of a nitrous oxide or a carbon dioxide supply system shall be observed daily during peak demand periods to determine whether they show frosting or condensation on the surface.

Where this is evident, the system shall be further inspected for evidence of leaks. Should excessive condensation or frosting occur, it may be necessary to upgrade to an Amico Microprocessor Digital Manifold with a built in heater kit.

PERIODIC STANDING PRESSURE TEST

At intervals of not more than 5 years, a 1-hour standing pressure test shall be made on each medical gas system to check for leakage.

Trouble Shooting

This section is intended to serve as a general guide for identifying the potential functional problems which occur in operation of Amico manifolds.

When an asterisk (*) appears beside the CORRECTIVE ACTION, the recommended procedure is to replace the whole unit in question, with a substitute unit, until repairs are completed on the original equipment.

Components removed for maintenance, must be serviced, repaired and tested, only by personnel qualified to work on equipment used in medical service. Only original manufacturer's parts, as supplied by Amico, may be used in the maintenance of Amico manifolds.

OPERATING PRESSURE REGULATOR FAULTS

SYMPTOM	CAUSE	CORRECTIVE ACTION
Gas leakage around operating pressure regulator body cap.	<ul style="list-style-type: none"> a. Loose cap. b. Diaphragm leak. 	<ul style="list-style-type: none"> 1. Tighten cap. 2. Replace regulator with substitute unit and change diaphragm.
Venting at intermediate relief valve.	<ul style="list-style-type: none"> a. Over pressure due to creeping or faulty regulation by operating pressure regulator. 	<ul style="list-style-type: none"> 1. Replace regulator with substitute unit and repair.

LINE PRESSURE REGULATOR FAULTS

SYMPTOM	CAUSE	CORRECTIVE ACTION
Pipeline not at desired pressure.	<ul style="list-style-type: none"> a. Line regulator not set correctly. 	<ul style="list-style-type: none"> 1. Set line regulator to value specified on (page 8) Line Regulator.
Required gas flow not available.	<ul style="list-style-type: none"> a. Line regulator not set correctly. 	<ul style="list-style-type: none"> 1. Set line regulator to value specified on (page 5) Line Regulator.
Low pressure relief valve venting.	<ul style="list-style-type: none"> a. Line regulator not set correctly. 	<ul style="list-style-type: none"> 1. Set line regulator to value specified on (page 5) Line Regulator.

Cylinder Changing Procedures

1. KEEP THE MAIN BANK VALVE OPEN THROUGHOUT THESE PROCEDURES.
2. CLOSE CYLINDER VALVES ON ALL EMPTY CYLINDERS.
3. DISCONNECT PIGTAILS FROM CYLINDER VALVE OUTLETS USING AN APPROPRIATE WRENCH.
4. PLACE PROTECTIVE CAPS OVER THE CYLINDER VALVES OF THE EMPTY CYLINDERS AND MOVE THEM ASIDE.
5. REMOVE PROTECTIVE CAPS OF THE FULL CYLINDERS. VISUALLY INSPECT THE CYLINDER VALVES FOR DUST, GREASE OR OIL.
6. USING A CLEAN (LINT FREE) CLOTH, WIPE EACH CYLINDER VALVE OUTLET CLEAN. DO NOT USE YOUR FINGERS.
7. STANDING TO ONE SIDE, "CRACK" THE CYLINDER VALVES BY BRIEFLY OPENING AND CLOSING THEM TO BLOW OUT ANY DUST. MAKE SURE THEY ARE POINTING AWAY FROM YOU AND OTHER PERSONNEL.
8. CONNECT THE PIGTAILS TO THE CYLINDER VALVE OUTLETS AND TIGHTEN THE NUT WITH AN APPROPRIATE WRENCH.
9. VERY S-L-O-W-L-Y OPEN THE CYLINDER VALVE ON THE CYLINDER CLOSEST TO THE CONTROL CABINET. WATCH THE BANK PRESSURE DISPLAY ON THE FRONT OF THE CABINET TO MAKE SURE THE PRESSURE RISES SLOWLY TO THE FULL CYLINDER PRESSURE READING.
10. WAIT ONE FULL MINUTE.
11. PROCEED TO S-L-O-W-L-Y OPEN THE REMAINING CYLINDER VALVES ONE AT A TIME.



WARNING: High Pressure oxygen systems must be handled with CAUTION. Spontaneous combustion may result if oxygen comes in contact with grease or oil. Ensure that hands, gloves, clothing and tools are kept clean and free of oil and grease. Be careful not to introduce dust or other contaminants into the system when changing cylinders. Failure to comply with this procedure may be hazardous.



WARNING: Fire Hazard. DO NOT permit smoking, or any other source of ignition in area where the manifold is located, or near the relief valve vent outlet. Be certain that all connections are free of dirt, grease and oil. These substances burn with great intensity in air, enriched with oxygen, or nitrous oxide and some gas mixtures.

Ordering Information

The model number for the ALERT-2 ECONOMY MANIFOLD is as follows: **M2EC-D-HH-U-GAS**

The letters "EC" represents that it is an Economy Manifold.

The letter "D" represents the type of Line Regulators): D = NFPA, S = Single line.

"HH" represents High Pressure on both sides.

"U" represents language and color code: U = NFPA/USA, E = ISO/Canadian, F = ISO/French.

Replace "GAS" with the appropriate GAS service as follows:

Oxygen = OXY, Medical Air = AIR, Nitrous Oxide = N2O, Carbon Dioxide = CO2 and Nitrogen = NIT.

Header-bars are sold separately: **M2-HBXS-04U-GAS**

"X" represents staggered header bar.

"T" represents straight header bar.

"S" represents stainless steel pigtails.

"C" represents copper steel pigtails.

"04" represents the number of cylinders (2*2).

"U" represents language and color code: U = NFPA/USA, E = ISO/Canadian.

Replace "GAS" with the appropriate GAS service.

ECONOMY MANIFOLD PARTS LIST

ITEM	DESCRIPTION	MODEL NUMBER
	Air Manifold Assembly	M2EC-D-HH-U-AIR
	Carbon Dioxide Manifold Assembly	M2EC-D-HH-U-CO2
	Nitrous Oxide Manifold Assembly	M2EC-D-HH-U-N2O
	Nitrogen Manifold Assembly	M2EC-D-HH-U-NIT
	Oxygen Manifold Assembly	M2EC-D-HH-U-OXY
18	Operating pressure regulator for Nitrogen	M2-X-MAN-18L-EN (Left Side) M2-X-MAN-18R-EN (Right Side)
18	Operating pressure regulator Oxy, N2O, Air & CO2	M2-X-MAN-18L-EC (Left Side) M2-X-MAN-18R-EC (Right Side)
18	Repair kit Operating pressure regulator Nitrogen	M2-REG250-RK-HP
18	Repair kit operating pressure regulator for Oxy, N2O, Air & CO2	M2-REG250-RK-LP

ITEM	DESCRIPTION	MODEL NUMBER
33	Operating check valve for all gases	M-X-MAN-33B
41	Operating pressure relief valve Nitrogen	M-X-MAN-72W-300
41	Operating pressure relief valve Oxy, N2O, Air & CO2	M-X-MAN-72W-200
42	Line pressure regulator for Nitrogen	M2-X-MAN-42E-RN (Right Side) M2-X-MAN-42E-LN (Left Side)
42	Line pressure regulator for Oxy, N2O, Air & CO2	M2-X-MAN-42E-R (Right Side) M2-X-MAN-42E-L (Left Side)
72	Line pressure relief valve for Nitrogen	M-X-MAN-72W-200
72	Line pressure relief valve for Oxy, N2O, Air & CO2	M-X-MAN-72W-075
	Plug & Chain assembly - Air	M-X-HB-NUT-AIR
	Plug & Chain assembly - CO2	M-X-HB-NUT-CO2
	Plug & Chain assembly - N2O	M-X-HB-NUT-N2O
	Plug & Chain assembly - Nit	M-X-HB-NUT-NIT
	Plug & Chain assembly - Oxy	M-X-MAN-36
	Copper pigtail c/w Check valve - Air	M-X-HB-PTC-AIR
	Copper pigtail c/w Check valve - CO2	M-X-HB-PTC-CO2
	Copper pigtail c/w Check valve - N2O	M-X-HB-PTC-N2O
	Copper pigtail c/w Check valve - Nit	M-X-HB-PTC-NIT
	Copper pigtail c/w Check valve - Oxy	M-X-HB-PTC-OXY
	Stainless pigtail c/w Check valve - Air	M-X-HB-PTS-AIR
	Stainless pigtail c/w Check valve - CO2	M-X-HB-PTS-CO2
	Stainless pigtail c/w Check valve - N2O	M-X-HB-PTS-N2O
	Stainless pigtail c/w Check valve - Nit	M-X-HB-PTS-NIT
	Manifold wall bracket	M2-X-MAN-SUP
	Header bar wall bracket	M-X-HB-WBRKT
	High pressure inlet valve (Stainless Steel Handle)	M-X-HB-HPVLV-A

Appendix A

Economy Manifold Layout

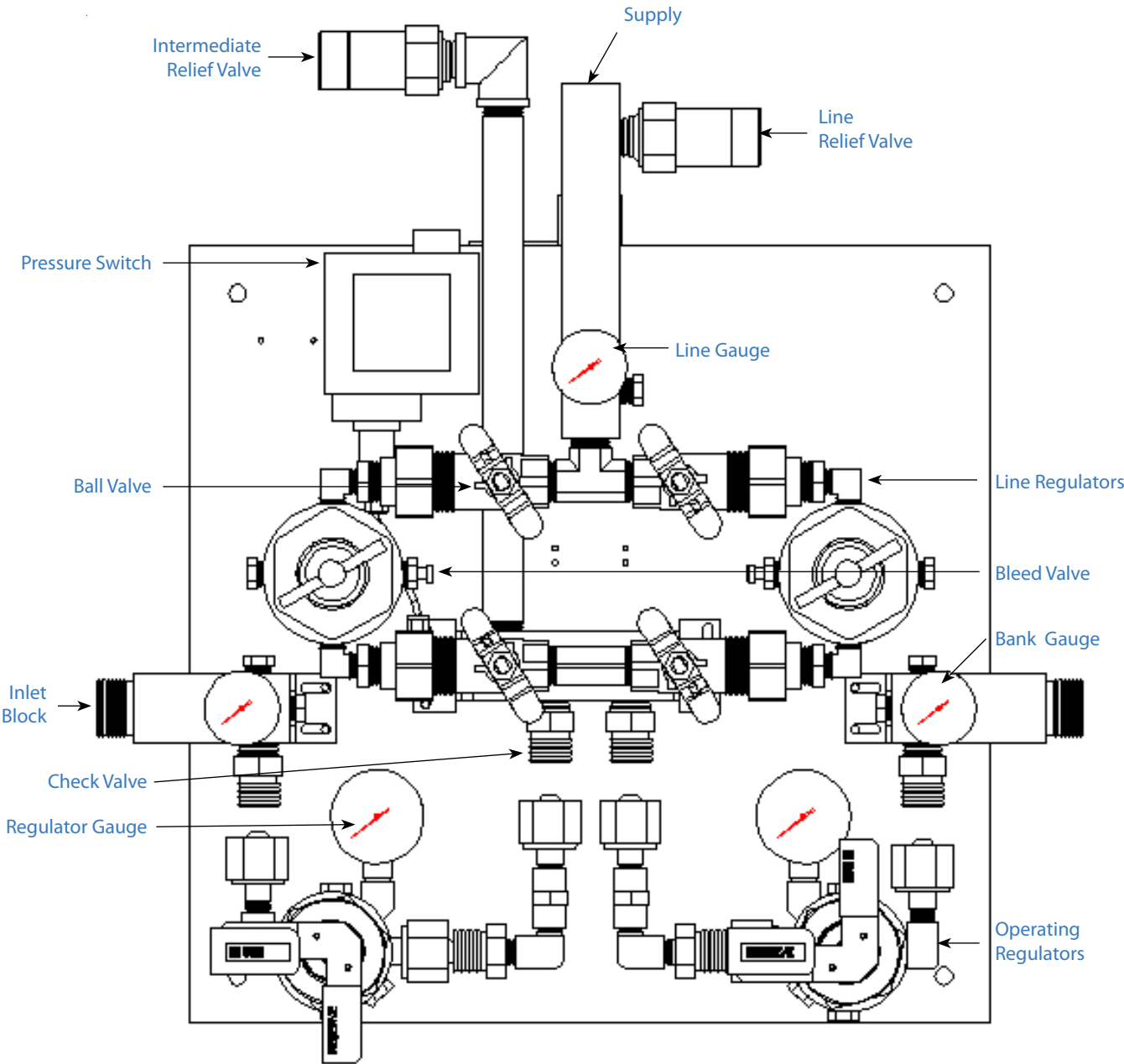

Piping Schematic Diagram - NFPA

Normal Operating & Relief Pressures (PSI)				
	Oxygen & Air	Nitrous Oxide	Carbon Dioxide	Nitrogen
A	2,200	745	1,000	2,200
B	150	150	150	275
C	55	55	55	170
D	75	75	75	225
E	225	225	225	350

ITEM	DESCRIPTION
1	Pig-Tail Check Valve
2	Cylinder Valve
3	High Pressure Inlet Valve
4	Operating Pressure Regulator
5	Check Valve
6	Line Pressure Regulator
7	2-Way Valve
8	Line Pressure Relief Valve
9	Operating Pressure Relief Valve
10	Bleed Valve

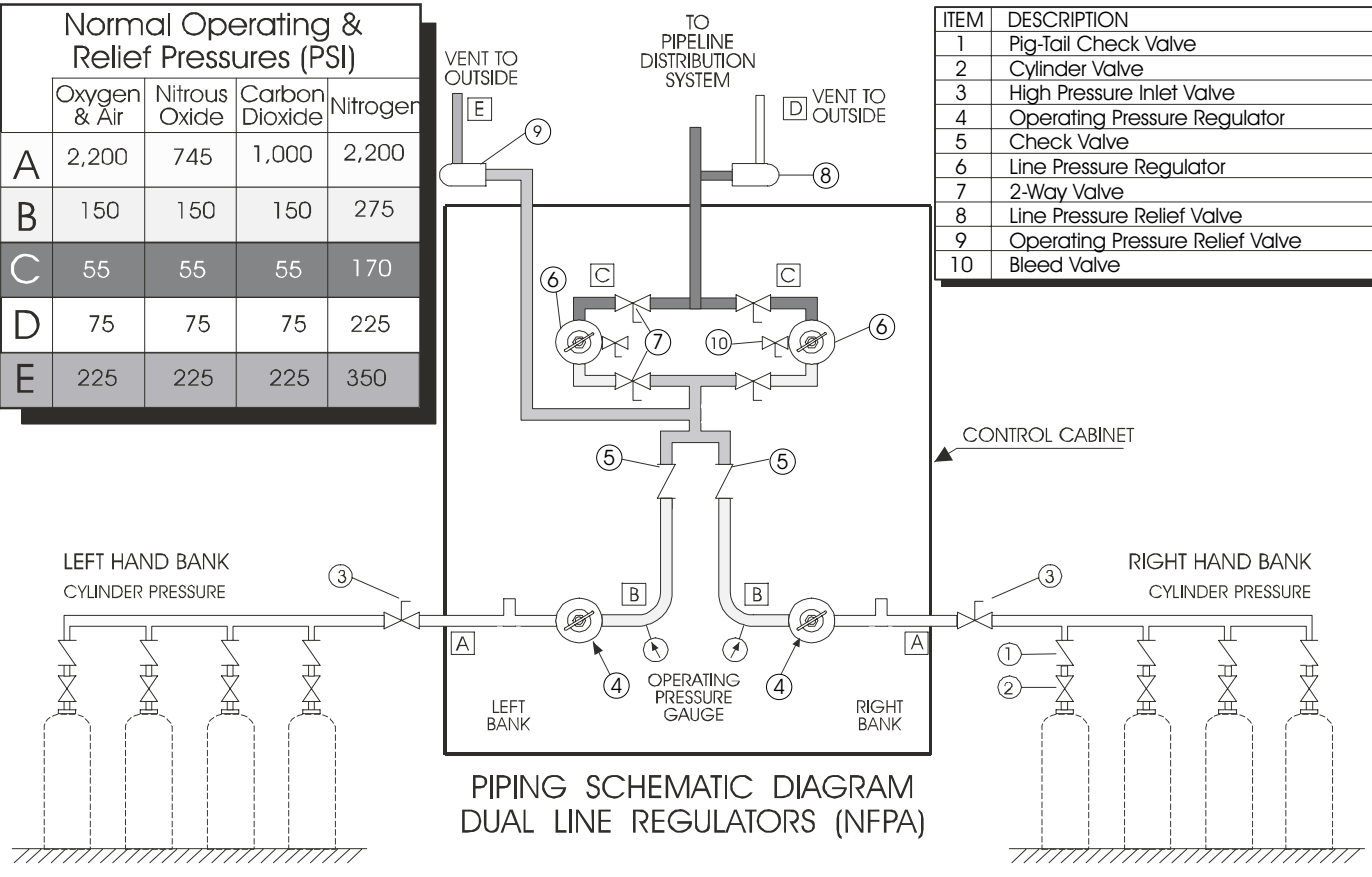

Wiring of Remote Alarm Buzzer

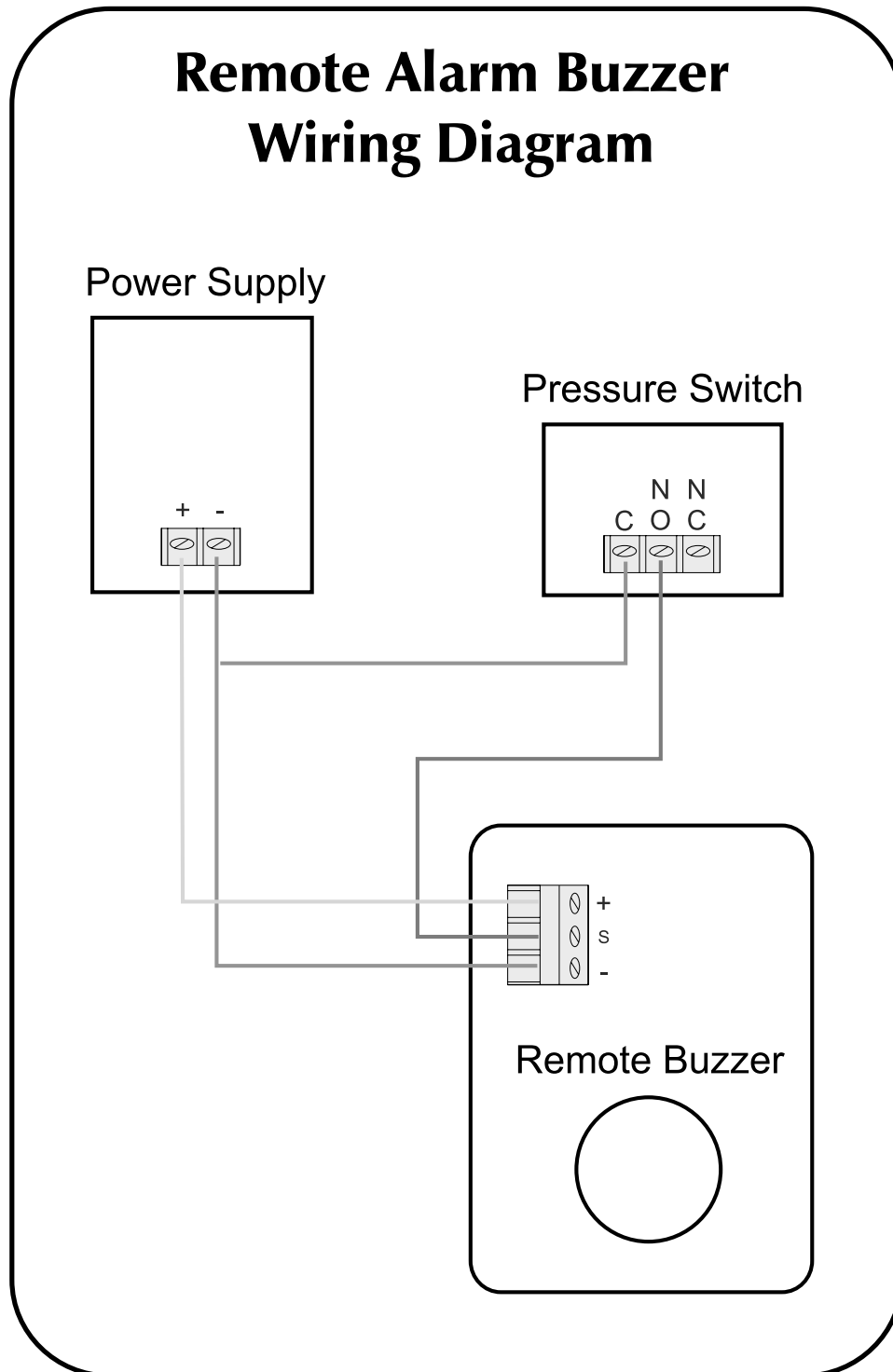

Support Bracket Hole Pattern Layout

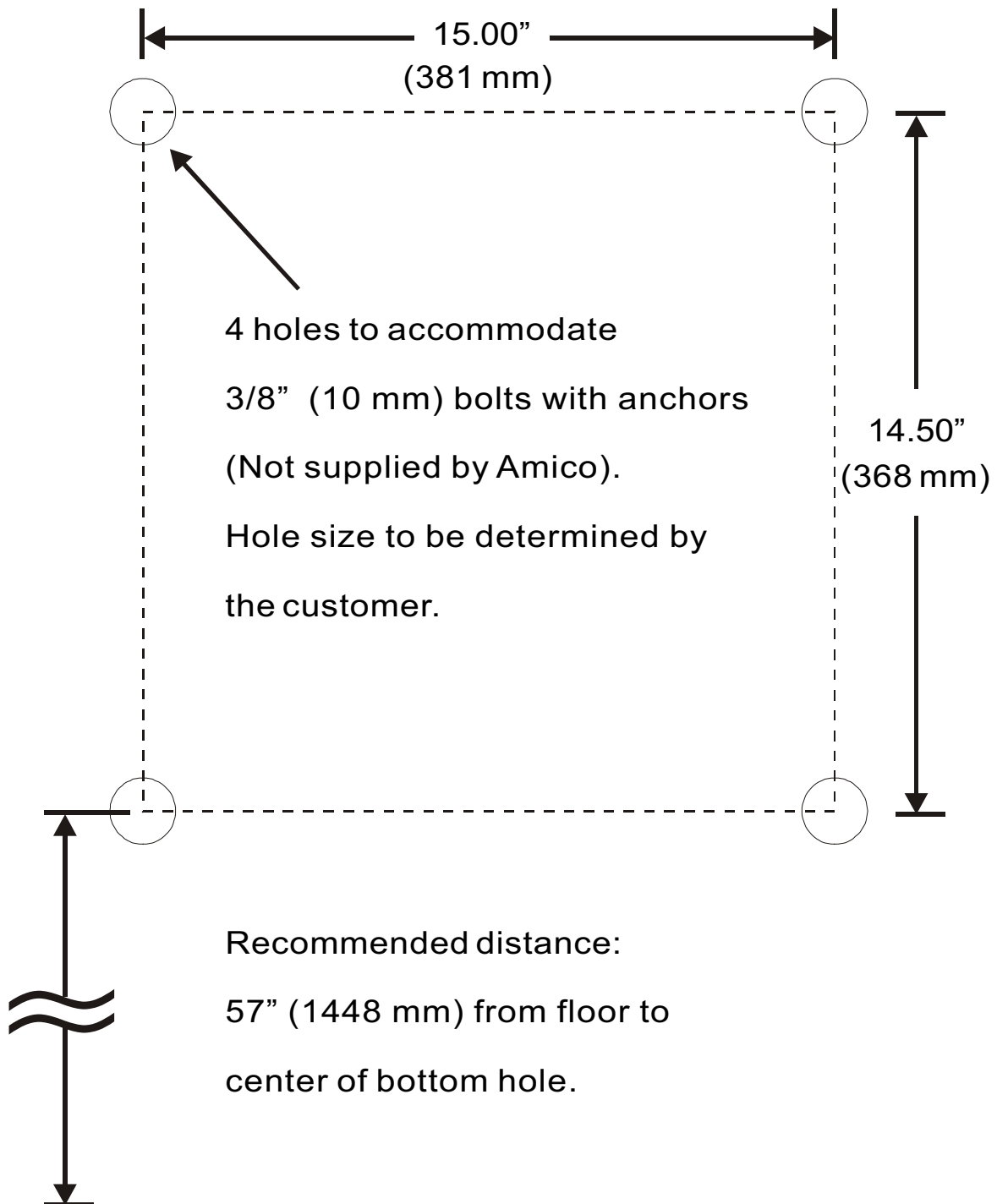

Warranty Policy

1. Amico Corporation warrants its Medical Gas Pipeline Equipment to be free from defects in material and workmanship for a period of twelve (12) months from the date of shipment. Within this period Amico will repair or replace any part on site, or at the factory, which is proven to be defective at Amico's cost.
2. Furthermore, Amico will warrant its material to be free from defect for an additional period of four (4) years (five (5) years from the date of shipment). Within this period, Amico will replace any part, at no charge, which is proven to be defective. Shipping and Installation costs after the first twelve (12) months will be borne by the Customer.
3. This warranty is valid only when the product has been properly installed according to Amico specifications, used in a normal manner and serviced according to factory recommendations. It does not cover failures due to damage which occurs in shipments or failures which resulted from accidents, misuse, abuse, neglect, mishandling, alteration, misapplication or damage that may be attributable to acts of God.
4. Amico shall not be liable for incidental or consequential damages resulting from the use of the equipment.
5. All claims for warranty must first be approved by Amico's Service Department (service@amico.com or 1-877-462-6426). A valid Return Goods Authorization (RGA) number must be obtained from Amico prior to commencement of any service work. Warranty work, which has not been pre-authorized by Amico, will not be reimbursed.



85 Fulton Way, Richmond Hill
Ontario, L4B 2N4, Canada

31 Sprague Avenue, Amityville
NY 11701, USA

Toll Free Tel: 1.877.462.6426
Toll Free Fax: 1.866.440.4986
Tel: 905.764.0800 | Fax: 905.764.0862
www.amico.com

represented by: